

Infant's bench

Cut list:

- 4 legs 1 ½" X 9"
- 2 long rails 5/8" X 11 ½"
- 2 long stretchers 1 ¼" X 11 ½"
- 2 short rails 5/8" X 9 ½"
- 2 short stretchers 1 ¼" X 9 ½"

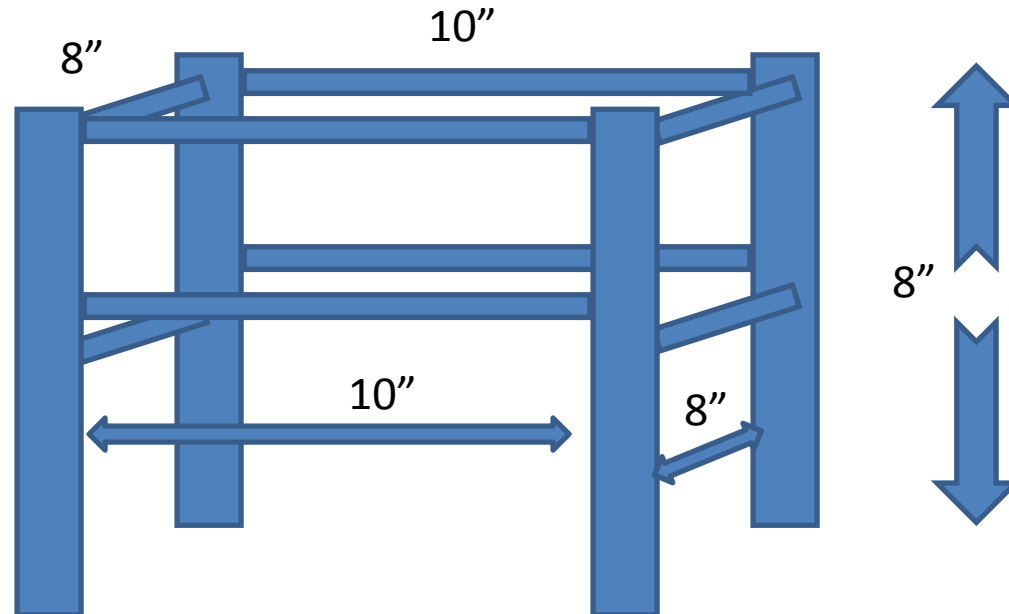



Infant's bench



TURNING

- Turn four legs to match 8" with waste block on tailstock to finish top smooth
- variations – square pommels or shaker locator lines: one on top, two staggered lower
- Turn two long stretchers with detail and 9/16" tenons that are 3/4" long each end
- turn two top rails, no detail but with 9/16" tenons 3/4" long each end;
- Turn two short stretchers full center belly and tapered ends to 9/16" tenon, 3/4"

ASSEMBLY

Using a "V-block" drill one hole for top of leg rail, drill upper mortise (repeat for each leg)
Using slip-joint pliers, crimp tenons each end of short rail and short stretcher,
Using yellow or white glue assemble each end and square on a flat bench, let dry
Using flat surface, drill upper leg rail and drill lower stretcher mortise (repeat each leg)
Using slip-joint pliers, crimp tenons each end of long rail and long stretcher,
Apply glue in holes for one end and insert rails and stretchers,
Apply glue in holes for other end and insert rails and stretchers;
Square bench to balance all four legs on a flat bench surface for drying.

USE: Make some very small person very happy with your handmade useful art.